

**PR**  
electronics



**2 2 8 6**

**Signal Controller**

No. 2286V101-UK  
From ser. no. 020060001



**EAC**

**CE**

- DK** ▶ PR electronics A/S tilbyder et bredt program af analoge og digitale signalbehandlingsmoduler til industriel automation. Programmet består af Isolatorer, Displays, Ex-barrierer, Temperaturtransmittere, Universaltransmittere mfl. Vi har modulerne, du kan stole på i selv barske miljøer med elektrisk støj, vibrationer og temperaturudsving, og alle produkter opfylder de strengeste internationale standarder. Vores motto »Signals the Best« er indbegrebet af denne filosofi - og din garanti for kvalitet.
- UK** ▶ PR electronics A/S offers a wide range of analog and digital signal conditioning devices for industrial automation. The product range includes Isolators, Displays, Ex Interfaces, Temperature Transmitters, and Multifunctional Devices. You can trust our products in the most extreme environments with electrical noise, vibrations and temperature fluctuations, and all products comply with the most exacting international standards. »Signals the Best« is the epitome of our philosophy - and your guarantee for quality.
- FR** ▶ PR electronics A/S offre une large gamme de produits pour le traitement des signaux analogiques et numériques dans tous les domaines industriels. La gamme de produits s'étend des transmetteurs de température aux afficheurs, des isolateurs aux interfaces SI, jusqu'aux modules universels. Vous pouvez compter sur nos produits même dans les conditions d'utilisation sévères, p.ex. bruit électrique, vibrations et fluctuations de température. Tous nos produits sont conformes aux normes internationales les plus strictes. Notre devise »SIGNALS the BEST« c'est notre ligne de conduite - et pour vous l'assurance de la meilleure qualité.
- DE** ▶ PR electronics A/S verfügt über ein breites Produktprogramm an analogen und digitalen Signalverarbeitungsgeräte für die industrielle Automatisierung. Dieses Programm umfasst Displays, Temperaturtransmitter, Ex- und galvanische Signaltrenner, und Universalgeräte. Sie können unsere Geräte auch unter extremen Einsatzbedingungen wie elektrisches Rauschen, Erschütterungen und Temperaturschwingungen vertrauen, und alle Produkte von PR electronics werden in Übereinstimmung mit den strengsten internationalen Normen produziert. »Signals the Best« ist Ihre Garantie für Qualität!

# SIGNAL CONTROLLER

## TYPE 2286

### CONTENTS

Warning.....	2
Safety instructions.....	3
How to dismantle system 2200.....	5
Applications.....	6
Technical characteristics.....	6
Inputs.....	6
Functions .....	7
Output .....	8
Electrical specifications.....	9
Order .....	11
Hardware programming.....	11
Block diagram 2286A .....	12
Block diagram 2286B .....	13
Routing diagram.....	14
Programming / operating the function keys .....	16
Selection of function / description of functions.....	21



**GENERAL**

## **WARNING**

This module is designed for connection to hazardous electric voltages. Ignoring this warning can result in severe personal injury or mechanical damage. To avoid the risk of electric shock and fire, the safety instructions of this manual must be observed and the guidelines followed.

The electrical specifications must not be exceeded, and the device must only be applied as described in the following. Prior to the commissioning of the device, this manual must be examined carefully.

Only qualified personnel (technicians) should install this device. If the equipment is used in a manner not specified by the manufacturer, the protection provided by the equipment may be impaired.



**HAZARD-  
OUS  
VOLTAGE**

## **WARNING**

Until the device is fixed, do not connect hazardous voltages to the device. The following operations should only be carried out on a disconnected device and under ESD safe conditions:

Dismantlement of the device for setting of DIP-switches and jumpers.

General mounting, connection and disconnection of wires.

Troubleshooting the device.



**Repair of the device and replacement of circuit breakers must be done by PR electronics A/S only.**



**INSTAL-  
LATION**

## **WARNING**

To keep the safety distances, devices with two built-in relays must not be connected to both hazardous and non-hazardous voltages on the same device's relay contacts.

SYSTEM 2200 must be mounted in socket type S3B Releco (order no 7023).

## SYMBOL IDENTIFICATION



**Triangle with an exclamation mark:** Warning / demand.  
Potentially lethal situations.



**The CE mark** proves the compliance of the device with the requirements of the directives.



**The double insulation symbol** shows that the device is protected by double or reinforced insulation.

## SAFETY INSTRUCTIONS

### DEFINITIONS

Hazardous voltages have been defined as the ranges: 75 to 1500 Volt DC, and 50 to 1000 Volt AC.

Technicians are qualified persons educated or trained to mount, operate, and also troubleshoot technically correct and in accordance with safety regulations.

**Operators**, being familiar with the contents of this manual, adjust and operate the knobs or potentiometers during normal operation.

### RECEIPT AND UNPACKING

Unpack the device without damaging it and check whether the device type corresponds to the one ordered. The packing should always follow the device until this has been permanently mounted.

### ENVIRONMENT

Avoid direct sunlight, dust, high temperatures, mechanical vibrations and shock, as well as rain and heavy moisture. If necessary, heating in excess of the stated limits for ambient temperatures should be avoided by way of ventilation.

All devices fall under Installation Category II, Pollution Degree 1, and Insulation Class II.

### MOUNTING

Only technicians who are familiar with the technical terms, warnings, and instructions in the manual and who are able to follow these should connect the device.

Should there be any doubt as to the correct handling of the device, please contact your local distributor or, alternatively

**PR electronics A/S**  
**www.prelectronics.com**

Mounting and connection of the device should comply with national legislation for mounting of electric materials, i.e. wire cross section, protective fuse, and location. Descriptions of Input / Output and supply connections are shown in the block diagram and side label.

*The following apply to fixed hazardous voltages-connected devices:*

The max. size of the protective fuse is 10 A and, together with a power switch, it should be easily accessible and close to the device. The power switch should be marked with a label telling it will switch off the voltage to the device.

### **CALIBRATION AND ADJUSTMENT**

During calibration and adjustment, the measuring and connection of external voltages must be carried out according to the specifications of this manual. The technician must use tools and instruments that are safe to use.

### **NORMAL OPERATION**

Operators are only allowed to adjust and operate devices that are safely fixed in panels, etc., thus avoiding the danger of personal injury and damage. This means there is no electrical shock hazard, and the device is easily accessible.

### **CLEANING**

When disconnected, the device may be cleaned with a cloth moistened with distilled water.

### **LIABILITY**

To the extent the instructions in this manual are not strictly observed, the customer cannot advance a demand against PR electronics A/S that would otherwise exist according to the concluded sales agreement.

## HOW TO DISMANTLE SYSTEM 2200

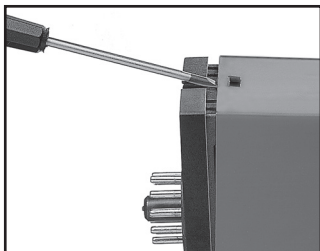

**Picture 1.**

The back panel of the device is detached from the housing by way of a screwdriver.

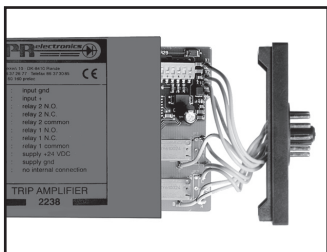

**Picture 2.**

After this, the back panel can be pulled out together with the PCB, but please notice the position of the PCB as there is a number of different positions in the house. Do not pull the wires unnecessarily, instead pull the PCB. Switches and jumpers can now be moved. When assembling the back plate and housing, please make sure no wires are stuck.

# SIGNAL CONTROLLER 2286

- *Multiple functions*
- *Programmable from front*
- *3-digit LED display*
- *Analogue or Pt100 input*
- *Relay outputs*
- *Max. 50% offset*

## Applications

PID on/off controller, PI step controller or 3-band controller with analogue or Pt100 input. As trip amplifier with setpoint adjustment through external current / voltage signal with neutral zone surrounding the setpoint. Especially suitable in applications where easy 11-pole relay socket mounting is required for instance in a panel. Possibility for readout of process data through the built-in display.

## Technical characteristics

### General

The 2286 is microprocessor-controlled and basic-calibrated. This means that the input and output can be programmed acc. to the requested signal range without any re-adjustment. Thereby a high degree of accuracy and flexibility are ensured. The output consists of two relays with a make contact connected to a common point. The user interface consists of a 3-digit display and 3 function keys in the front. The interface is used to change a function or an input signal range.

### Inputs

#### Analogue inputs - 2286A

The A and B channels can be freely programmed via the front keys and JP1 and JP2 to current in the range 0...20 mA or voltage in the range 0...10 VDC with a max. offset of 50% of the actual max. value.

#### Pt100 input - 2286B

Linearised Pt100 temperature input in the range -99...+850 °C with 3-wire connection. The temperature range can be scaled via the front keys. Max. offset is 50% of max. temperature, min. span is 50°C.



## Functions

### PID on/off controller

Accurate setting of the regulation parameters XP (proportional band), TI (integrating time) and TD (differentiating time), with the units selected as XP %, TI s and TD s. Minimum XP is 0.01% equivalent to a gain of 10,000. By setting TI and TD to 0, the function will be a pure proportional controller. The controller adjusts the time interval between the pulses on the output, the pulse width is set by the parameter TP. When the process value is outside the proportional band, the output gives a constant up / down signal until the process value is brought within the proportional band. Hereafter the output pulses with a variable interval depending on the distance from the setpoint. The neutral zone is an accepted deviation in relation to an ideal output value, where no function is required on the output. The neutral zone is set in %. The setpoint can be selected as internal (external setpoint input disabled) or as external (current / voltage).

### PI step controller

The PI step controller is especially suitable for control of motor-driven valves, throttle valves and dosage units. When the process value is outside the proportional band, the output will give a constant up / down signal until the process value is brought within the proportional band. Hereafter the output pulses with a variable OFF time depending on the distance from the setpoint. A selected minimum ON time protects the motor against too short activations. The regulation parameters are XP (proportional band), tAU (exponential average time of the active relay state) - functions as integrating time, tP (the shortest active time of the relays) and nEU (neutral zone) - the band that the process is to be kept within. The setpoint can be selected as internal (external setpoint input disabled) or as external (current / voltage).

### 3-band controller

The neutral zone is an accepted deviation in relation to the setpoint where no function is required on the output. The neutral zone is set in % of the input span and centered around the setpoint. If the process input drops below the neutral zone, the UP relay is activated until the process input rises to the setpoint value. Similarly the DOWN relay is activated if the process input rises above the neutral zone, and releases when the input signal drops to the setpoint value. The setpoint can be selected as internal (external setpoint input disabled) or as external (current / voltage).

## **dl/dt function**

The function monitors the size of the decrease or increase (dl) of the input within a set period of time (dt). If the set ratio, i.e. change per time unit, is exceeded, the relays will be activated. A time constant can be selected for the averaging of the input value.

## **Comparator with an external setpoint**

The process value is compared to the external setpoint, and if the two signals differ, a relay will be activated, i.e. the UP relay for process values larger than the setpoint plus a  $\frac{1}{2}$  neutral zone, and the DOWN relay for values below the setpoint minus a  $\frac{1}{2}$  neutral zone.

## **Trip amplifier with an external setpoint**

The relay function can be selected for increasing / decreasing or window. As a trip amplifier the relays can be activated individually when the input value differs from the setpoint plus or minus the neutral zone. The window function activates a relay when the process value differs by more than the neutral zone from the setpoint. The two relays can be activated independently by a common setpoint.

## **Output**

2 relay outputs with a make contact connected to a common point.  
Relay outputs can be installed in PELV/SELV circuits.

## Electrical specifications

### Specifications range:

-20°C to +60°C

### Common specifications:

Supply voltage .....	19.2...28.8 VDC
Internal consumption .....	2.5 W
Max. consumption.....	3 W
Isolation test / operation.....	3.75 kVAC / 250 VAC
Signal / noise ratio .....	Min. 60 dB
Signal dynamics, input.....	20 bit
Proportional band (XP).....	0.01...999 %
Gain, 1/XP = .....	0.1...10000 gg
Integrating time (TI).....	0...999 s
Differentiating time (TD).....	0...999 s
Neutral zone (nEU).....	0...99.9 %
Pulse time (TP).....	0.01...400 s
Minimum pulse time (TP).....	0.01...10 s
Response time .....	< 60 ms
Calibration temperature .....	20...28°C
Temperature coefficient.....	< ± 0.01% of span/°C
Linearity error .....	< ± 0.1% of span
Effect of supply voltage change .....	< ± 0.002% of span/%V

### Auxiliary voltages:

Reference voltage .....

Reference voltage .....	2.5 VDC ± 0.5% / 15 mA
-------------------------	------------------------

EMC immunity influence .....

EMC immunity influence .....	< ± 0.5%
------------------------------	----------

Relative air humidity .....

Relative air humidity .....	< 95% RH (non-cond.)
-----------------------------	----------------------

Dimensions (HxWxD) .....

Dimensions (HxWxD) .....	84.5 x 35.5 x 80.5 mm (excl. pins)
--------------------------	------------------------------------

Protection degree.....

Protection degree.....	IP50
------------------------	------

Weight .....

Weight .....	140 g
--------------	-------

### Electrical specifications - INPUT:

#### Current input:

Measurement range.....

Measurement range.....	0...20 mA
------------------------	-----------

Min. measurement range (span).....

Min. measurement range (span).....	4 mA
------------------------------------	------

Max. offset .....

Max. offset .....	50% of selected max. value
-------------------	----------------------------

Input resistance.....

Input resistance.....	50 Ω
-----------------------	------

**Voltage input:**

Measurement range .....	0...10 VDC
Min. measurement range (span) .....	200 mV
Max. offset .....	50% of selected max. value
Input resistance .....	Nom. 10 M $\Omega$

**Pt100 input 2286B:**

Measurement range.....	-99...+850°C
Min. measurement range (span) .....	50°C
Max. offset .....	50% of selected max. value
Cable resistance per wire (max.).....	25 $\Omega$
Sensor current.....	Nom. 1.25 mA
Response time .....	< 100 ms
Basic accuracy.....	< $\pm 0.2^\circ\text{C}$
Temperature coefficient:	
span < 100°C .....	$\pm 0.01^\circ\text{C}/^\circ\text{C}_{\text{amb}}$ .
span > 100°C.....	$\pm 0.01\%$ of span/ $^\circ\text{C}_{\text{amb}}$ .
Immunity influence:	
span $\leq 100^\circ\text{C}$ .....	1% of span
span $\geq 100^\circ\text{C}$ .....	0.5% of span
Effect of sensor cable resistance .....	< 0.002 $\Omega/\Omega$

**Electrical specifications - OUTPUT:****Relay outputs:**

Max. voltage .....	250 VRMS
Max. current.....	2 A / AC
Max. AC power .....	500 VA
Max. load at 24 VDC.....	1 A

**Observed authority requirements:**

EMC 2004/108/EC .....	EN 61326-1
LVD 2006/95/EC.....	EN 61010-1
PELV/SELV .....	IEC 364-4-41 and EN 60742
EAC TR-CU 020/2011.....	EN 61326-1

**Standard:**

**of span** = of the presently selected range

## Order

Type	Input
2286	Voltage / current : A
	Temperature : B

## Hardware programming

### INPUT:

<b>Channel A</b>			
0...20 mA	JP2	ON	MENU 2.3 = I
0...10 VDC	JP2	OFF	MENU 2.3 = U
<b>Channel B</b>			
0...20 mA	JP1	ON	MENU 3.3 = I
0...10 VDC	JP1	OFF	MENU 3.3 = U

# BLOCK DIAGRAM 2286A

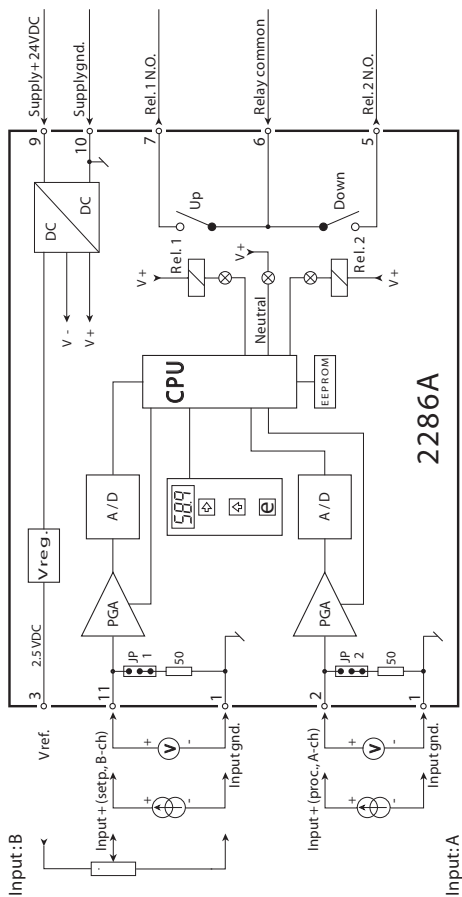

# BLOCK DIAGRAM 2286B

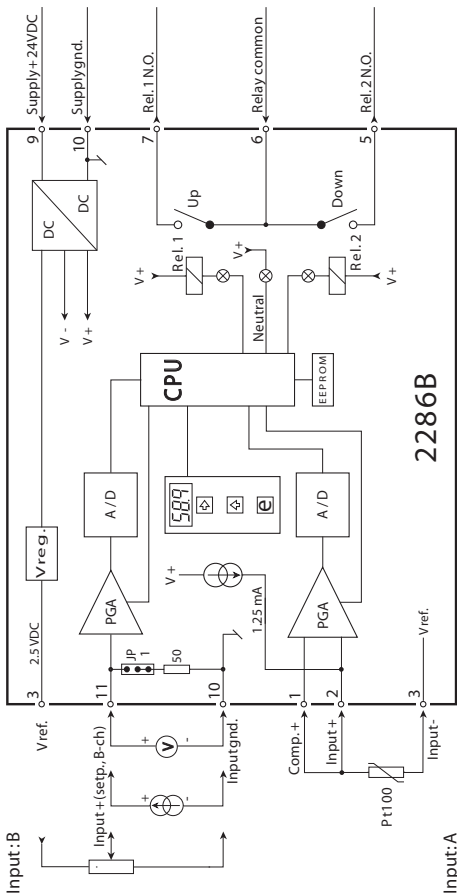

# ROUTING DIAGRAM

## Programming

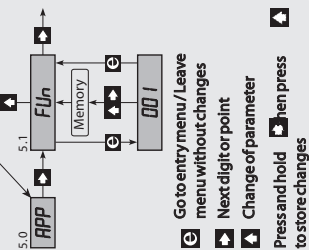

If no buttons are pressed for a period of 20 minutes, display returns to stage 0.0.

## Fast Setting

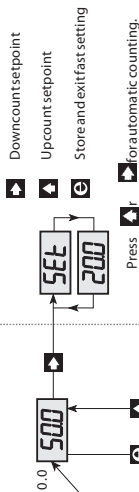

## 1.0 Parameter line

- Menu 5.1 = 1  
Function: PIDON / OFF contr.
- 1.1 **SEE** Setpoint
  - 1.2 **HP** Proportional band
  - 1.3 **TI** Integrating time
  - 1.4 **ED** Differential time
  - 1.5 **EP** Pulse width
  - 1.6 **nEU** Neutral zone
  - 1.7 **IE** Setpoint int./external
  - 1.8 **DI** Direct/inverting
- Menu 5.1 = 2  
Function: PI step controller
- 1.1 **SEE** Setpoint
  - 1.2 **HP** Proportional band
  - 1.3 **LRI** Relay time constant
  - 1.4 **EP** Minimum pulse time
  - 1.5 **nEU** Neutral zone
  - 1.6 **HSE** Pulse width hysteresis
  - 1.7 **IE** Setpoint int./external
  - 1.8 **DI** Direct/inverting

- Menu 5.1 = 3  
Function: 3-point controller
- 1.1 **SEE** Setpoint
  - 1.2 **nEU** Neutral zone
  - 1.3 **IE** Setpoint int./external
  - 1.4 **DI** Direct/inverting

- Menu 5.1 = 4  
Function: dl/dt function
- 1.1 **LRI** Tau value
  - 1.2 **DI1** drelay1
  - 1.3 **DI2** drelay2

Parameters

1.0

0.0



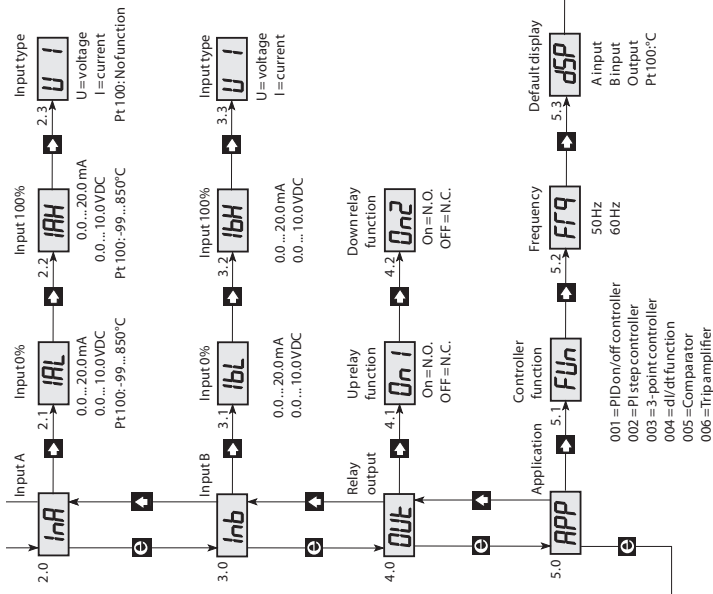

- 1.4 **H51** Hysteresis dl1/dt
- 1.5 **H52** Hysteresis dl2/dt
- 1.6 **dE3** Sampling (s\*1000)
- 1.7 **dE0** Sampling (s)

Menu 5.1 = 5

- Function: Comparator
- 1.1 **nEU** Neutral zone
- 1.2 **H5E** Hysteresis

Menu 5.1 = 6



- Function: Trip amplifier
- 1.1 **EF1** Trip function relay 1
- 1.2 **EF2** Trip function relay 2
- 1.3 **nE1** Neutral zone relay 1
- 1.4 **nE2** Neutral zone relay 2
- 1.5 **H51** Hysteresis relay 1
- 1.6 **H52** Hysteresis relay 2

040 = enable change in all stages  
 --- = disable change



# PROGRAMMING / OPERATING THE FUNCTION KEYS

## DOCUMENTATION FOR ROUTING DIAGRAM

### General



Menus and sub menus are selected by the 3 function keys ,  and  as outlined in the routing diagram.

Activating  will display the current value.

In entry menus, the digit that can be changed will flash. Active digit position is shifted by the  key, and the value is changed by the  key.

When the decimal point flashes, its position can be changed by the  key.

In parameter selection menus you switch between the parameters by the  key.

Store by first activating  and then  simultaneously.

To return to previous menu without changing the parameters - activate .

If a non-valid value is entered, the display will show Err for 2 s and then return to the entry menu with the initial parameters.

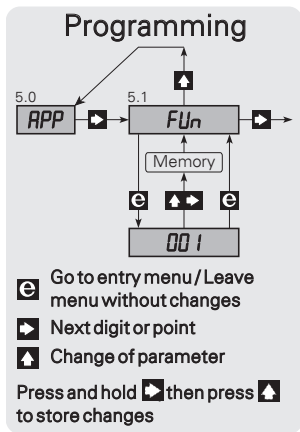

### 0.0 Default - The selection is displayed in menu 5.3.

The display returns to default at power ON, or if no keys have been activated for a period of 20 minutes.

## ▣ Fast Setting - Short cut key for change of setpoint

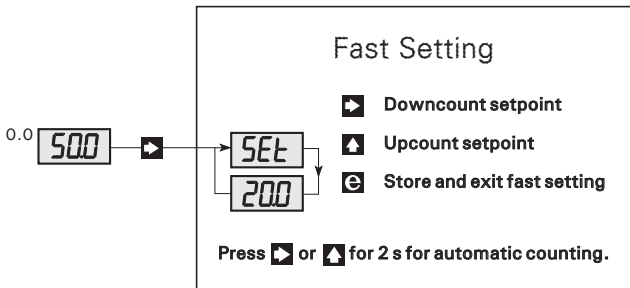

When internal setpoint setting has been selected, a fast change of setpoint is possible by way of the Fast Setting function. In this menu, the function keys have a special function, as ▴ upcounts the setpoint and ▣ downcounts the setpoint from the value it had when activated.

The setpoint value is displayed in % of the input span.

Activate e to store the displayed setpoint value.

## 1.0 PAr - Parameter menu - entry of parameters.

The parameter menu bar varies according to the selected function in menu 5.1 -FUn. See the description of function under FUn.

### Menu 5.1 = { 1: PID on off controller }

#### 1.1 SEt - Setpoint.

Possible selections are 0...99.9% of the input span.

#### 1.2 hP - Proportional band.

Possible selections are 0.01...999%.

#### 1.3 tI - Integrating time.

Possible selections are 0...999 s.

#### 1.4 tD - Differentiating time.

Possible selections are 0...999 s.

#### 1.5 tP - Pulse time, the active time of the relays.

Valid selections are 0.01...400 s.

**1.6 nEU - Neutral zone, accepted deviation in relation to the ideal output value.**

Possible selections are 0.1...99.9%.

**1.7 IE - Internal or external setpoint.**

Possible selections are I - internal, or E - external.

Selection of internal or external setpoint. When internal setpoint has been selected, input B is disabled and the setpoint value is set in menu 1.1. When external setpoint has been selected, the signal type and range of the setpoint are set in menu 3.0.

**1.8 dl - Direct / Inverted controlling method.**

Possible selections are dlr - direct, or InU - inverted.

Selection of direct or inverted setting range. When the selection is direct, a process value > the setpoint will result in an active UP relay. When the selection is inverted, a process value > the setpoint will result in an active DOWN relay.

**Menu 5.1 = { 2: PI step controller }**

**1.1 SEt - Setpoint.**

Possible selections are 0...99.9% of the input span.

**1.2 hP - Proportional band.**

Possible selections are 0.01...999%.

**1.3 tAU - Exponential average time of the active relay state.**

Possible selections are 0.1...999 s.

The period in which the relay is active is exponentially averaged and forms part of the control loop.

**1.4 tP - Minimum pulse time, shortest active time for the relays.**

Valid selections are 0.01...10 s.

**1.5 nEU - Neutral zone, accepted deviation in relation to the setpoint.**

Possible selections are 0.1...99.9% of the input span.

**1.6 HSt - Pulse width hysteresis.**

Setting should be:  $0 < \text{HSt} < \text{nEU}$

Possible selections are 0...99.9%.

**1.7 IE - Internal or external setpoint.**

Possible selections are I - internal, or E - external.

Selection of internal or external setpoint. When internal has been selected, input B is disabled and the setpoint value is set in menu 1.1. When external has been selected, the signal type and range of the setpoint are set in menu 3.0.

### **1.8 dl - Direct / Inverted controlling method.**

Possible selections are dlr - direct, or InU - inverted.

When a direct controlling method has been selected, a process value > the setpoint will result in an active UP relay. When an inverted controlling method has been selected, a process value > the setpoint will result in an active DOWN relay.

### **Menu 5.1 = { 3: 3-point controller }**

#### **1.1 SEt - Setpoint.**

Possible selections are 0...99.9% of the input span.

#### **1.2 nEU - Neutral zone, accepted deviation in relation to the setpoint.**

Possible selections are 0.1...99.9% of the input span.

#### **1.3 IE - Internal or external setpoint.**

Possible selections are I - internal, or E - external.

Selection of internal or external setpoint. When internal has been selected, input B is disabled and the setpoint value is set in menu 1.1. When an external setpoint has been selected, the signal type and range of the setpoint are set in menu 3.0.

#### **1.4 dl - Direct / Inverted controlling method.**

Possible selections are dlr - direct, or InU - inverted.

Selection of direct or inverted controlling method. When direct has been selected, a process value > the setpoint will result in an active UP relay.

When inverted has been selected, a process value > the setpoint will result in an active DOWN relay.

### **Menu 5.1 = { 4: dl/dt function }**

#### **1.1 tAU - Exponential averaging of the input.**

Possible selections are 0.00...999 s.

#### **1.2 dl1 - Change of input in % of the input span for UP relay.**

Possible selections are -99...100%.

#### **1.3 dl2 - Change of input in % of input span for DOWN relay.**

Possible selections are -99...100%.

#### **1.4 HS1 - Hysteresis in % of input span for UP relay.**

Possible selections are 0...200%.

#### **1.5 HS2 - Hysteresis in % of input span for DOWN relay.**

Possible selections are 0...200%.

**1.6 dt3 - Requested time interval between the samplings in s \* 1000.**

Possible selections are 0...003 s \* 1000.

**1.7 dt0 - Requested time interval between the samplings in s.**

Possible selections are 0...999 s.

**1.6 + 1.7(dt3 + dt0) The sum of the 2 parameters.**

Possible selections are 0.02...3600 s.

#### **Menu 5.1 = { 5: comparator }**

**1.1 nEU - Neutral zone in % of the input span.**

Possible selections are 0.00...100%.

**1.2 HSt - Hysteresis in % of the input span.**

Possible selections are 0.00...100%.

#### **Menu 5.1 = { 6: trip amplifier }**

**1.1 tF1 - Trip function for UP relay.**

Possible selections are increasing / decreasing or window.

**1.2 tF2 - Trip function for DOWN relay.**

Possible selections are increasing / decreasing or window.

**1.3 nE1 - Neutral zone in % of the input span for UP relay.**

Possible selections are 0.00...100%.

**1.4 nE2 - Neutral zone in % of the input span for DOWN relay.**

Possible selections are 0.00...100%.

**1.5 HS1 - Hysteresis in % of the input span for UP relay.**

Possible selections are 0.00...100%.

**1.6 HS2 - Hysteresis in % of the input span for DOWN relay.**

Possible selections are 0.00...100%.

#### **2.0 InA - Setting of signal input A.**

**2.1 IAL - Setting of 0% input signal.**

Possible selections are current 0.0...20.0 mA, or voltage 0.0...10.0 VDC.

For devices with a Pt100 input, the valid 0% temperature is -99...850°C.

**2.2 IAH - Setting of 100% input signal.**

Possible selections are current 0.0...20.0 mA, or voltage 0.0...10.0 VDC.

For devices with a Pt100 input, the valid 100% temperature is -99...850°C.

### 2.3 UI - Selection of current / voltage input.

Possible selections are I - current input, or U - voltage input.

Selection of I for current, or U for voltage input. For devices with a Pt100 input, this menu has no function.

See the hardware programming for correct jumper setting.

## 3.0 Inb - Setting of signal input B.

### 3.1 IbL - Setting of 0% input signal.

Possible selections are current 0.0...20.0 mA, or voltage 0.0...10.0 VDC.

### 3.2 IbH - Setting of 100% input signal.

Possible selections are current 0.0...20.0 mA, or voltage 0.0...10.0 VDC.

### 3.3 UI - Selection of current / voltage input.

Possible selections are I - current input, or U - voltage input.

Selection of I for current, or U for voltage input.

See the hardware programming for correct jumper setting.

## 4.0 Out - Setting of relay function.

### 4.1 On1 - Setting of UP relay function.

Possible selections are On = N.O., or OFF = N.C. relay function.

### 4.2 On2 - Setting of DOWN relay function.

Possible selections are On = N.O., or OFF = N.C. relay function.

## Selection of function / description of functions

### 5.0 APP - Selection of function.

#### 5.1 FUn - Selection of function.

Possible selections are:

#### 001 = PID on/off controller:

The controller controls the time interval between the active relay outputs whereas the ON time of the relays is set by the parameter  $T_p$ . When the process value is outside the proportional band, the UP / DOWN relay is permanently activated. When the process value is within the proportional band, the UP / DOWN relay will be de-activated within a variable interval depending on the distance from the setpoint. The neutral zone is the percentage On time ( $T_p\%$ ), where no function is required on the output.

In a correctly tuned PID controller the constant error will be eliminated. This means that at a correctly tuned  $X_p$ ,  $T_i$ ,  $T_d$ , and  $T_p$  a regulation accuracy can be obtained close to what the process value can be measured to. It is therefore important that the proportional band  $X_p$ ,

the integrating time  $T_i$ , the differentiating time  $T_d$ , and the pulse time  $T_p$  are tuned according to the individual process. Before setting the parameters, the method of regulation directly / inverted must be determined. Direct controlling results in an active UP relay when the process value  $>$  the setpoint. Inverted controlling results in an active DOWN relay when the process value  $>$  the setpoint.

Inexperienced users may use the following "rule-of-thumb" for determining the process parameters:

1. The pulse time  $T_p$  is set to a value so short that the process value is barely affected by the supplied energy.
2. Set  $X_p$  at max.,  $T_i$  and  $T_d$  to 0 (only proportional controlling).
3. Reduce  $X_p$  until the process starts oscillating.
4. Increase  $X_p$  twofold.
5. Set  $T_i$  at max.
6. Reduce  $T_i$  until the process starts oscillating again.
7. Increase  $T_i$  twofold.
8. If the controller is too slow reaching its setpoint, the differential controller can be activated. The differentiating function augments the control signal proportionally to the rise time of the process signal. Therefore the setting varies according to the process.

#### **002 = PI step controller:**

The controller controls motor-driven valves, throttle valves and dosage units via the UP / DOWN relays by a variable OFF time according to the difference between the process value and setpoint and to the selected regulation parameters. The variable parameters are:  $X_p$  - the proportional band,  $tAU$  - the exponential average time of the active relay state - functions as integrating time,  $tP$  - the shortest active time of the relays,  $nEU$  - the neutral zone, i.e. the band that the process is to be kept within, and  $HSt$  - the pulse width hysteresis within the neutral zone.

#### **The PI step controller can be set as follows:**

1. The setting method direct / inverted is determined. Direct controlling results in an active UP relay when the process value  $>$  the setpoint. Inverted controlling results in an active DOWN relay when the process value  $>$  the setpoint.
2. The minimum pulse width  $tP$  is set in s. A reasonable start value is 0.5% of the actuating time - the period from closed to open state of the actuator.



3. The neutral zone nEU is set as the band which the controlling process is to be kept within. The neutral zone is set in % of the input span.
4. The hysteresis HSt is set in % of the input span. A value of nEU/4 is a reasonable start value. In processes with large dead times, HSt can with advantage be diminished.
5. Set the proportional band Xp (hP) to max. = 999% and tAU to max. = 999 s.
6. Reduce Xp (hP) until the process starts oscillating.
7. Increase Xp (hP) twofold.
8. Reduce tAU until the process starts oscillating.
9. Increase tAU twofold.

#### **003 = 3-point controller:**

The neutral zone, which is set in % of the input span, is placed symmetrically around the setpoint setting. When the process input is lower than the neutral zone, the UP relay is activated until the process input increases to the setpoint value. When the process input is higher than the neutral zone, the DOWN relay is activated until the process input decreases to the setpoint value. The setting parameters are SET setpoint, nEU neutral zone, dlr direct, and InU inverted. Direct / inverted reverses the state of the UP / DOWN relays.

#### **004 = dl/dt control:**

The function monitors the size of the decrease or increase (dl) of the input within a set period of time (dt). A time constant for the input value can be selected. The limit of the magnitude of the decrease / increase (dl) is entered in the menus 1.2 and 1.3. The period of time (dt) over which the change is to be monitored is entered in the menus 1.6 and 1.7. At a positive (dl/dt), the relays will be activated when the change of the input signal exceeds the value (dl) in menu 1.2 or 1.3 within the set period of time (dt) in menus 1.6 and 1.7. The relays will be de-activated when the change is lower than the (dl) minus HS (the hysteresis) per (dt).

At a negative (dl/dt), the relays will be activated when the change of the input signal drops below the value (dl) in menu 1.2 or 1.3 within the set period of time (dt) in menus 1.6 and 1.7. The relays will be de-activated when the change is larger than the (dl) plus HS (the hysteresis) per (dt).

### **005 = Comparator with an external setpoint:**

The process input A is compared with the external setpoint on input B. When the two signals are within the neutral zone, no relays are active. When A is smaller than B minus  $\frac{1}{2}$  neutral zone, the DOWN relay changes its state. When A is larger than B plus  $\frac{1}{2}$  neutral zone, the UP relay changes its state. The hysteresis is placed inside the neutral zone.

### **006 = Trip amplifier / window with an external setpoint:**

Input A is connected to the process signal and input B is connected to an external setpoint.

The relay trip function can be selected as TF = Increment, decrement, or Window. If the trip function has been selected as 1.1 = InC, the UP relay will be activated, when the input value (input A) is larger than the external setpoint (input B). The relay will be de-activated again when the input value is smaller than the setpoint minus the hysteresis. If the function 1.1 = dEC has been selected, the UP relay will be activated when the input value is smaller than the setpoint. The relay will be de-activated again when the input value is larger than the setpoint plus the hysteresis.

The neutral zone will offset the setpoint by the value entered in 1.3 nE1 and 1.4 nE2 - positive for increasing (TF = InC), and negative for decreasing (TF = DEC) input value (input A). If you request the relays to be activated at different input values, two different neutral zones must be entered.

The same description applies to DOWN relay.

The two trip relays use the same external setpoint (input B).

#### **Window:**

When the input signal is within the setpoint  $\pm$  the neutral zone, the relay is inactive. The relay will be activated when the input signal exceeds the setpoint  $\pm$  the neutral zone.

When the input signal approaches the setpoint from a higher value, the relay will be de-activated at the setpoint plus the neutral zone minus the hysteresis.

When the input signal approaches the setpoint from a lower value, the relay will be de-activated at the setpoint minus the neutral zone plus the hysteresis.

This description applies to both UP and DOWN relay.

## **5.2 FrQ - Frequency.**

Possible selections are 50 or 60 Hz.

Selection of common mode frequency suppression.

## **5.3 dSP - Default display.**

Possible selections are the A / B input or output.

The display is the percentage of Full Span. For modules with a Pt100 input, also °C can be displayed.

## **5.4 PAS - Password.**

Possible selections are 0... 999.

When the password is 040, changes can be made in all menu points.

When the password is <> 040, programming is blocked in all menu points but open to reading of settings.



### Displays

Programmable displays with a wide selection of inputs and outputs for display of temperature, volume and weight, etc. Feature linearization, scaling, and difference measurement functions for programming via PReset software.



### Ex interfaces

Interfaces for analog and digital signals as well as HART® signals between sensors / I/P converters / frequency signals and control systems in Ex zone 0, 1 & 2 and for some devices in zone 20, 21 & 22.



### Isolation

Galvanic isolators for analog and digital signals as well as HART® signals. A wide product range with both loop-powered and universal isolators featuring linearization, inversion, and scaling of output signals.



### Temperature



























A wide selection of transmitters for DIN form B mounting and DIN rail devices with analog and digital bus communication ranging from application-specific to universal transmitters.



### Universal

PC or front programmable devices with universal options for input, output and supply. This range offers a number of advanced features such as process calibration, linearization and auto-diagnosis.



- 

[www.preelectronics.fr](http://www.preelectronics.fr)  

[sales-fr@preelectronics.com](mailto:sales-fr@preelectronics.com)
- 

[www.preelectronics.de](http://www.preelectronics.de)  

[sales-de@preelectronics.com](mailto:sales-de@preelectronics.com)
- 

[www.preelectronics.es](http://www.preelectronics.es)  

[sales-es@preelectronics.com](mailto:sales-es@preelectronics.com)
- 

[www.preelectronics.it](http://www.preelectronics.it)  

[sales-it@preelectronics.com](mailto:sales-it@preelectronics.com)
- 

[www.preelectronics.se](http://www.preelectronics.se)  

[sales-se@preelectronics.com](mailto:sales-se@preelectronics.com)
- 

[www.preelectronics.com](http://www.preelectronics.com)  

[sales-uk@preelectronics.com](mailto:sales-uk@preelectronics.com)
- 

[www.preelectronics.com](http://www.preelectronics.com)  

[sales-us@preelectronics.com](mailto:sales-us@preelectronics.com)
- 

[www.preelectronics.cn](http://www.preelectronics.cn)  

[sales-cn@preelectronics.com](mailto:sales-cn@preelectronics.com)
- 

[www.preelectronics.be](http://www.preelectronics.be)  

[sales-be@preelectronics.com](mailto:sales-be@preelectronics.com)

## Head office

Denmark  
 PR electronics A/S  
 Lerbakken 10  
 DK-8410 Rønede

[www.preelectronics.com](http://www.preelectronics.com)  
[sales@preelectronics.dk](mailto:sales@preelectronics.dk)  
 tel. +45 86 37 26 77  
 fax +45 86 37 30 85



QUALITY SYSTEM AND ENVIRONMENTAL MANAGEMENT SYSTEM  
 DS/EN ISO 9001  
 DS/EN ISO 14001

