

PR
electronics



4 2 2 2

**Universal
I/f converter**

No. 4222V101-UK
From ser. no. 060867001



- DK** ▶ PR electronics A/S tilbyder et bredt program af analoge og digitale signalbehandlingsmoduler til industriel automation. Programmet består af Isolatorer, Displays, Ex-barrierer, Temperaturtransmittere, Universaltransmittere mfl. Vi har modulerne, du kan stole på i selv barske miljøer med elektrisk støj, vibrationer og temperaturudsving, og alle produkter opfylder de strengeste internationale standarder. Vores motto »Signals the Best« er indbegrebet af denne filosofi - og din garanti for kvalitet.
- UK** ▶ PR electronics A/S offers a wide range of analog and digital signal conditioning devices for industrial automation. The product range includes Isolators, Displays, Ex Interfaces, Temperature Transmitters, and Multifunctional Devices. You can trust our products in the most extreme environments with electrical noise, vibrations and temperature fluctuations, and all products comply with the most exacting international standards. »Signals the Best« is the epitome of our philosophy - and your guarantee for quality.
- FR** ▶ PR electronics A/S offre une large gamme de produits pour le traitement des signaux analogiques et numériques dans tous les domaines industriels. La gamme de produits s'étend des transmetteurs de température aux afficheurs, des isolateurs aux interfaces SI, jusqu'aux modules universels. Vous pouvez compter sur nos produits même dans les conditions d'utilisation sévères, p.ex. bruit électrique, vibrations et fluctuations de température. Tous nos produits sont conformes aux normes internationales les plus strictes. Notre devise »SIGNALS the BEST« c'est notre ligne de conduite - et pour vous l'assurance de la meilleure qualité.
- DE** ▶ PR electronics A/S verfügt über ein breites Produktprogramm an analogen und digitalen Signalverarbeitungsgeräte für die industrielle Automatisierung. Dieses Programm umfasst Displays, Temperaturtransmitter, Ex- und galvanische Signaltrenner, und Universalgeräte. Sie können unsere Geräte auch unter extremen Einsatzbedingungen wie elektrisches Rauschen, Erschütterungen und Temperaturschwingungen vertrauen, und alle Produkte von PR electronics werden in Übereinstimmung mit den strengsten internationalen Normen produziert. »Signals the Best« ist Ihre Garantie für Qualität!

UNIVERSAL I/f CONVERTER

4222

CONTENTS

Warning.....	4
Symbol identification	5
Safety instructions.....	5
How to dismantle system 4000.....	7
Advanced features	8
Application.....	8
Technical characteristics.....	8
PR 4501 Display / programming front.....	9
Mounting / demounting the PR 4501/4511.....	10
Applications.....	11
Order codes	12
Electrical specifications.....	12
Configuration of sensor error detection.....	16
Display readout on the 4501	16
Display outside range.....	16
Sensor error detection limits.....	17
Signal conditioning limits	17
Error indications.....	17
Connections	18
Block diagram.....	19
Configuration / operating the function keys.....	20
Routing diagram.....	23
Routing diagram, Advanced settings (ADV.SET).....	26
Scrolling help text in display line 3.....	27



GENERAL

WARNING

This device is designed for connection to hazardous electric voltages. Ignoring this warning can result in severe personal injury or mechanical damage. To avoid the risk of electric shock and fire, the safety instructions of this manual must be observed and the guidelines followed. The specifications must not be exceeded, and the device must only be applied as described in the following. Prior to the commissioning of the device, this manual must be examined carefully. Only qualified personnel (technicians) should install this device. If the equipment is used in a manner not specified by the manufacturer, the protection provided by the equipment may be impaired.



**HAZARDOUS
VOLTAGE**

WARNING

Until the device is fixed, do not connect hazardous voltages to the device.

The following operations should only be carried out on a disconnected device and under ESD safe conditions:

- General mounting, connection and disconnection of wires.
- Troubleshooting the device.



Repair of the device and replacement of circuit breakers must be done by PR electronics A/S only.



**INSTALL-
LATION**

WARNING

SYSTEM 4000 must be mounted on a DIN rail according to DIN 46277.



WARNING

Do not open the front plate of the device as this will cause damage to the connector for the display / programming front PR 4501. This device contains no DIP-switches or jumpers.

SYMBOL IDENTIFICATION



Triangle with an exclamation mark: Warning / demand.
Potentially lethal situations.



The CE mark proves the compliance of the device with the essential requirements of the directives.



The double insulation symbol shows that the device is protected by double or reinforced insulation.

SAFETY INSTRUCTIONS

DEFINITIONS

Hazardous voltages have been defined as the ranges: 75 to 1500 Volt DC, and 50 to 1000 Volt AC.

Technicians are qualified persons educated or trained to mount, operate, and also troubleshoot technically correct and in accordance with safety regulations.

Operators, being familiar with the contents of this manual, adjust and operate the knobs or potentiometers during normal operation.

RECEIPT AND UNPACKING:

Unpack the device without damaging it. The packing should always follow the device until this has been permanently mounted. Check at the receipt of the device whether the type corresponds to the one ordered.

ENVIRONMENT

Avoid direct sunlight, dust, high temperatures, mechanical vibrations and shock, as well as rain and heavy moisture. If necessary, heating in excess of the stated limits for ambient temperatures should be avoided by way of ventilation.

All devices fall under Installation Category II, Pollution Degree 1, and Insulation Class II.

MOUNTING

Only technicians who are familiar with the technical terms, warnings, and instructions in the manual and who are able to follow these should connect the device.

Should there be any doubt as to the correct handling of the device, please contact your local distributor or, alternatively,

PR electronics A/S
www.prelectronics.com

Mounting and connection of the device should comply with national legislation for mounting of electric materials, i.a. wire cross section, protective fuse, and location. Descriptions of input / output and supply connections are shown in the block diagram and side label.

The following apply to fixed hazardous voltages-connected devices:

The max. size of the protective fuse is 10 A and, together with a power switch, it should be easily accessible and close to the device. The power switch should be marked with a label indicating that it will switch off the voltage to the device.

Year of manufacture can be taken from the first two digits in the serial number.

UL INSTALLATION REQUIREMENTS

Use 60/75°C copper conductors only.

For use only in pollution degree 2 or better.

Max. ambient temperature 60°C

Max. wire size..... AWG 26-14

UL file number E231911

CALIBRATION AND ADJUSTMENT

During calibration and adjustment, the measuring and connection of external voltages must be carried out according to the specifications of this manual. The technician must use tools and instruments that are safe to use.

NORMAL OPERATION

Operators are only allowed to adjust and operate devices that are safely fixed in panels, etc., thus avoiding the danger of personal injury and damage. This means there is no electrical shock hazard, and the device is easily accessible.

CLEANING

When disconnected, the device may be cleaned with a cloth moistened with distilled water.

LIABILITY

To the extent that the instructions in this manual are not strictly observed, the customer cannot advance a demand against PR electronics A/S that would otherwise exist according to the concluded sales agreement.

HOW TO DISMANTLE SYSTEM 4000

First, remember to demount the connectors with hazardous voltages.

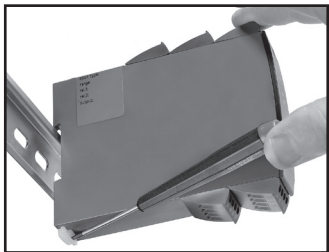

Picture 1:

Detach the device from the DIN rail by lifting the bottom lock.

UNIVERSAL I/f CONVERTER 4222

- *Input for RTD, TC, Ohm, potentiometer, mA and V*
- *Frequency output NPN, PNP and TTL*
- *Generates frequencies from 0.001...25000 Hz*
- *2-wire supply > 16 V*
- *Universal AC or DC supply*

Advanced features

- Programmable by way of detachable display front (4501), process calibration, signal simulation, password protection, error diagnostics and help text available in several languages.

Application

- Linearised, electronic temperature measurement with RTD or TC sensor.
- Conversion of linear resistance variation to a frequency signal, e.g. from solenoids and butterfly valves or linear movements with attached potentiometer.
- Power supply and signal isolator for 2-wire transmitters.
- Process control by way of a frequency signal transmitted to e.g. a PLC or a process computer.
- Galvanic separation and conversion of analogue signals to frequency signals.

Technical characteristics

- When 4222 is used in combination with the 4501 display / programming front, all operational parameters can be modified to suit any application. As the 4222 is designed with electronic hardware switches, it is not necessary to open the device for setting of DIP-switches.
- A green front LED indicates normal operation.
- Continuous check of vital stored data for safety reasons.
- 3-port 2.3 kVAC galvanic isolation.

PR 4501 DISPLAY / PROGRAMMING FRONT



Functionality

The simple and easily understandable menu structure and the explanatory help texts guide you effortlessly and automatically through the configuration steps, thus making the product very easy to use. Functions and configuration options are described in the section "Configuration / operating the function keys".

Application

- Communications interface for modification of operational parameters in 4222.
- Can be moved from one 4222 device to another and download the configuration of the first converter to subsequent converters.
- Fixed display for readout of process data and status.

Technical characteristics

- LCD display with 4 lines; line 1 (H = 5.57 mm) shows input signal, line 2 (H = 3.33 mm) shows units. Line 3 alternates between digital output value and scaling (kHz, Hz, mHz, P/m, P/h, P/d) or shows TAG no. Line 4 shows tendency readout for the input signal and communication status.
- Programming access can be blocked by assigning a password. The password is saved in the converter in order to ensure a high degree of protection against unauthorised modifications to the configuration.

Mounting / installation

- Click 4501 onto the front of 4222.

MOUNTING / DEMOUNTING THE PR 4501/4511

1: Insert the taps of 4501/4511 into the holes at the top of the device.

2: Swing 4501/4511 into place.

Demounting of 4501/4511

3: Push the release button on the bottom of 4501/4511 and swing 4501/4511 up.

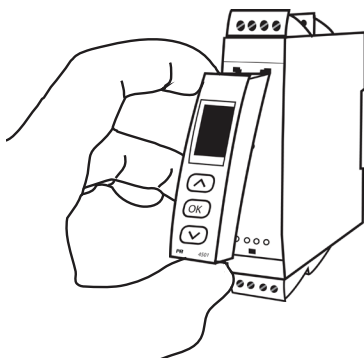
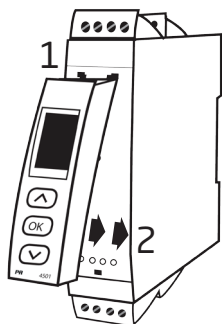

APPLICATIONS

Input signals:

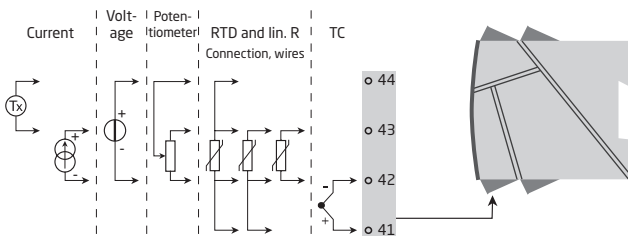

Output signals:

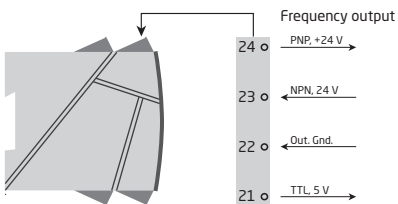

Supply:

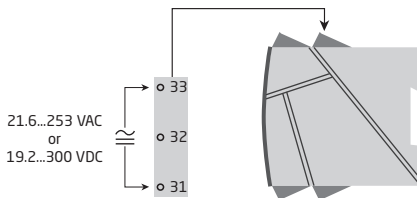

Order codes

4222 = Universal I/f converter

4501 = Display / programming front

Electrical specifications

Specifications range	-20°C to +60°C
Calibration temperature	20...28°C
Relative humidity.....	< 95% RH (non-cond.)
Protection degree.....	IP20

Mechanical specifications

Dimensions (HxBxD)	109 x 23.5 x 104 mm
Dimensions, with 4501 / 4511 (HxBxD).....	109 x 23.5 x 116 / 131 mm
Weight	155 g
Weight with 4501 / 4511.....	170 g / 255 g
Max. wire size.....	1 x 2.5 mm ² stranded wire
Screw terminal torque	0.5 Nm

Common specifications

Supply voltage, universal	21.6...253 VAC, 50...60 Hz or 19.2...300 VDC
Max. consumption.....	≤ 2.5 W
Fuse.....	400 mA SB / 250 VAC
Isolation voltage, test / operation.....	2.3 kVAC / 250 VAC
Communications interface	Communication enabler 4511 Programming front 4501
Signal / noise ratio	Min. 60 dB (0...100 kHz)
Response time (0...90%, 100...10%), programmable:	
Temperature input.....	1...60 s
mA / V input.....	0,4...60 s

Accuracy, the greater of the general and basic values:

General values		
Input type	Absolute accuracy	Temperature coefficient
All	≤ ±0.1% of span	≤ ±0.01% of span / °C

Basic values		
Input type	Basic accuracy	Temperature coefficient
mA	$\leq \pm 4 \mu\text{A}$	$\leq \pm 0.4 \mu\text{A} / ^\circ\text{C}$
Volt	$\leq \pm 20 \mu\text{V}$	$\leq \pm 2 \mu\text{V} / ^\circ\text{C}$
Pt100	$\leq \pm 0.2^\circ\text{C}$	$\leq \pm 0.01^\circ\text{C} / ^\circ\text{C}$
Linear resistance	$\leq \pm 0.1 \Omega$	$\leq \pm 0.01 \Omega / ^\circ\text{C}$
Potentiometer	$\leq \pm 0.1 \Omega$	$\leq \pm 0.01 \Omega / ^\circ\text{C}$
TC type: E, J, K, L, N, T, U	$\leq \pm 1^\circ\text{C}$	$\leq \pm 0.05^\circ\text{C} / ^\circ\text{C}$
TC type: B, R, S, W3, W5, LR	$\leq \pm 2^\circ\text{C}$	$\leq \pm 0.2^\circ\text{C} / ^\circ\text{C}$

EMC immunity influence < $\pm 0.5\%$ of span
 Extended EMC immunity:
 NAMUR NE 21, A criterion, burst < $\pm 1\%$ of span

Auxiliary supplies:

2-wire supply (terminal 44...43)..... 25...16 VDC / 0...20 mA

RTD, linear resistance and potentiometer input:

Input for RTD types:

Pt10, Pt20, Pt50, Pt100, Pt200, Pt250, Pt300, Pt400, Pt500, Pt1000
 Ni50, Ni100, Ni120, Ni1000

Input type	Min. value	Max. value	Standard
Pt100	-200°C	+850°C	IEC60751
Ni100	-60°C	+250°C	DIN 43760
Lin. resistance	0 Ω	10000 Ω	-
Potentiometer	10 Ω	100 k Ω	-

Cable resistance per wire (max.), RTD..... 50 Ω

Sensor current, RTD..... Nom. 0.2 mA

Effect of sensor cable resistance

(3- / 4-wire), RTD < 0.002 Ω / Ω

Sensor error detection, RTD..... Yes

Short circuit detection, RTD < 15 Ω

TC input

Type	Min. value	Max. value	Standard
B	+400°C	+1820°C	IEC 60584-1
E	-100°C	+1000°C	IEC 60584-1
J	-100°C	+1200°C	IEC 60584-1
K	-180°C	+1372°C	IEC 60584-1
L	-200°C	+900°C	DIN 43710
N	-180°C	+1300°C	IEC 60584-1
R	-50°C	+1760°C	IEC 60584-1
S	-50°C	+1760°C	IEC 60584-1
T	-200°C	+400°C	IEC 60584-1
U	-200°C	+600°C	DIN 43710
W3	0°C	+2300°C	ASTM E988-90
W5	0°C	+2300°C	ASTM E988-90
LR	-200°C	+800°C	GOST 3044-84

Cold junction compensation (CJC)

via internally mounted sensor < ±1.0 °C

Sensor error detection, all TC types..... Yes

Sensor error current:

when detecting..... Nom. 2 µA

else 0 µA

Current input

Measurement range..... -1...25 mA

Programmable measurement ranges..... 0...20 and 4...20 mA

Input resistance..... Nom. 20 Ω + PTC 50 Ω

Sensor error detection:

loop break 4...20 mA..... Yes

Voltage input:

Measurement range..... -20 mV...12 VDC

Programmable measurement ranges..... 0...1 / 0.2...1 / 0...2.5 / 0.5...2.5 /

0...5 / 1...5 / 0...10 and 2...10 VDC

Input resistance..... Nom. 10 MΩ

Output

Frequency output

Frequency range..... 0...25000 Hz

Min. frequency (span)..... 0.001 Hz

Duty cycle (0...25000 Hz)..... 50% or

Programmable pulse time ($f \leq 500$ Hz)..... 1...1000 ms (max. 90% duty cycle)

PNP output

I _{out} max.....	30 mA
V _{out}	24 VDC ± 10%
C _{out}	10 nF
R _{out} typ.....	20 Ω
Electromechanical counter.....	24 V / 135 mA / 20 ms / ≤ 10 Hz

NPN output

I _{sink} max.....	150 mA
I _{sink} max. peak.....	300 mA
External voltage (terminal 23) max.....	55 VDC
C _{out}	10 nF
R _{out} typ.....	10 Ω

TTL output

I _{sink/source} max.....	15 mA
I _{sink/source} peak.....	100 mA
V _{out}	5 V ± 5%
C _{out}	10 nF
R _{out} typ.....	55 Ω

Sensor error detection

Programmable.....	0...26250 Hz
-------------------	--------------

Ex / I.S. approval

FM, applicable in.....	Class I, Div. 2, Group A, B, C, D Class I, Div. 2, Group IIC Zone 2
Max. ambient temperature for T5.....	60°C

Observed authority requirements

	Standard
EMC 2004/108/EC.....	EN 61326-1
LVD 2006/95/EC.....	EN 61010-1
FM.....	3600, 3611, 3810 and ISA 82.02.01
UL, Standard for Safety.....	UL 508
EAC TR-CU 020/2011.....	EN 61326-1

of span = of the currently selected measurement range

Configuration of sensor error detection

Module:	Configuration	Sensor error detection:
4222	OUT.ERR=NO	OFF
	Else:	ON

Display readout on the 4501

Display outside range

Display readout below min. / above max. (-1999, 9999):			
Input	Range	Flashing readout	Limit
All	All	-1999	Display readout < -1999
		9999	Display readout > 9999

Sensor error detection limits

Sensor error detection (SE.BR, SE.SH):			
Input	Range	Readout	Limit
CURR	Loop break (4...20 mA)	SE.BR	$\leq 3.6 \text{ mA}$; $> = 21 \text{ mA}$
POTM	All, SE.BR on all 3-wire	SE.BR	$> \text{ca. } 126 \text{ k}\Omega$
LIN.R	0...800 Ω	SE.BR	$> \text{ca. } 875 \text{ }\Omega$
	0...10 k Ω	SE.BR	$> \text{ca. } 11 \text{ k}\Omega$
TEMP	TC	SE.BR	$> \text{ca. } 750 \text{ k}\Omega / (1,25 \text{ V})$
	RTD: 2-, 3- and 4-wire	SE.BR	$> \text{ca. } 15 \text{ k}\Omega$
	No SE.SH for Pt10, Pt20 and Pt50	SE.SH	$< \text{ca. } 15 \text{ }\Omega$

Signal conditioning limits

Outside range readout (IN.LO, IN.HI): If the valid range of the A/D converter or the polynomial is exceeded.			
Input	Range	Readout	Limit
VOLT	0...1 V / 0.2...1 V	IN.LO	$< -25 \text{ mV}$
		IN.HI	$> 1.2 \text{ V}$
	0...2.5 / 0.5...2.5 / 0...5 V / 1...5 V / 0...10 V / 2...10 V	IN.LO	$< -25 \text{ mV}$
		IN.HI	$> 12 \text{ V}$
CURR	0...20 mA / 4...20 mA	IN.LO	$< -1.05 \text{ mA}$
		IN.HI	$> 25.05 \text{ mA}$
LIN.R	0...800 Ω	IN.LO	$< 0 \text{ }\Omega$
		IN.HI	$> 1075 \text{ }\Omega$
	0...10 k Ω	IN.LO	$< 0 \text{ }\Omega$
		IN.HI	$< 110 \text{ k}\Omega$
POTM	Min. readout = 0%, Max. readout = 100%	IN.LO	$< -0.5 \%$
		IN.HI	$> 100.5 \%$
TEMP	TC / RTD	IN.LO	$< \text{temperature range } -2^\circ\text{C}$
		IN.HI	$> \text{temperature range } +2^\circ\text{C}$

Error indications

Readout at hardware error		
Error search	Readout	Cause
Test of internal CJC sensor	CJ.ER	CJC sensor defect or temperature outside range
Checksum test of the configuration in FLASH	FL.ER	Error in FLASH
Communications test 4501 / 4222	NO.CO	Connection error
Check that input signal matches input configuration	IN.ER	1) Error levels on input
Check that saved configuration in 4501 matches module	TY.ER	Configuration is not 4222
! All error indications flash once per second. The help text explains the error.		
1) The error is reset by switching off and then switching on the supply voltage to the module.		

CONNECTIONS

Supply:

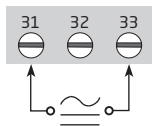

Inputs

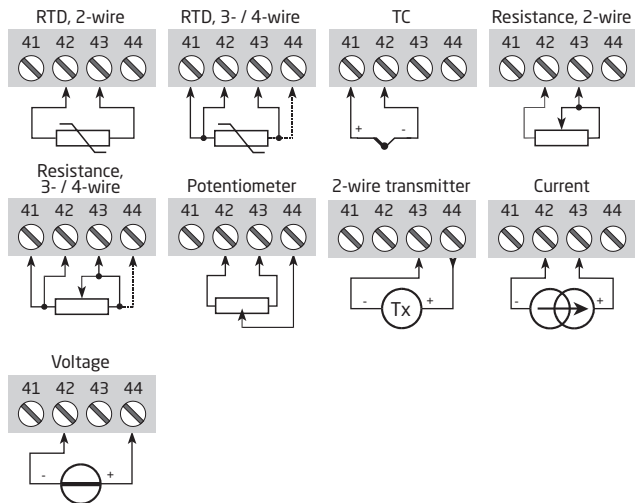

Outputs

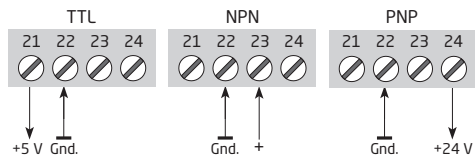

BLOCK DIAGRAM

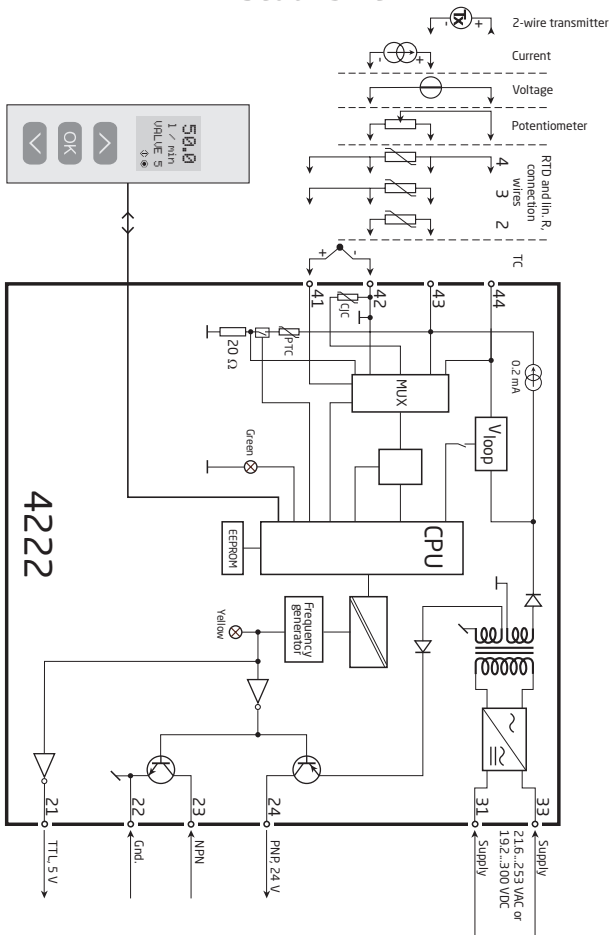

CONFIGURATION / OPERATING THE FUNCTION KEYS

Documentation for routing diagram.

In general

When configuring the 4222, you will be guided through all parameters and you can choose the settings which fit the application. For each menu there is a scrolling help text which is automatically shown in line 3 on the display.

Configuration is carried out by using the 3 function keys:

- ⬆ will increase the numerical value or choose the next parameter
- ⬇ will decrease the numerical value or choose the previous parameter
- OK will save the chosen value and proceed to the next menu

When configuration is completed, the display will return to the default state 1.0.

Pressing and holding OK will return to the previous menu or return to the default state (1.0) without saving the changed values or parameters.

If no key is activated for 1 minute, the display will return to the default state (1.0) without saving the changed values or parameters.

Further explanations

Password protection: Programming access can be blocked by assigning a password. The password is saved in the converter in order to ensure a high degree of protection against unauthorised modifications to the configuration. Default password 2008 allows access to all configuration menus.

Signal and sensor error info via display front 4501

Sensor error (see limits in the table) is displayed as SE.BR (sensor break) or SE.SH (sensor short). Signals outside the selected range (not sensor error, see table for limits) are displayed as IN.LO indicating low input signal or IN.HI indicating high input signal. The error indication is displayed in line 3 as text and at the same time the backlight flashes. Line 4 of the display is a status line which displays COM (flashing bullet) indicating correct functioning of 4501 and arrow up/down which indicates tendency readout of the input signal.

Signal and sensor error indication without display front

Status of the unit can also be read from the green LED in the front of the device.

Green flashing LED 13 Hz indicates normal operation.

Green flashing LED 1 Hz indicates sensor error.

Steady green LED indicates internal error.

Advanced functions

The unit gives access to a number of advanced functions which can be reached by answering "Yes" to the point "adv.set".

Display setup: Here you can adjust the brightness contrast and the backlight. Setup of TAG numbers with 6 alphanumeric. Selection of readout in line 3 of the display. This line can either show the digital output or the TAG number.

Two-point process calibration: The unit can be process-calibrated in 2 points to fit a given input signal. A low input signal (not necessarily 0%) is applied and the actual value is entered. Then a high signal (not necessarily 100%) is applied and the actual value is entered. If you accept to use the calibration, the unit will work according to this new adjustment. If you later reject this menu point or choose another type of input signal the unit will return to factory calibration.

Process simulation function: If you say "Yes" to the point "EN.SIM" it is possible to simulate an input signal by means of the arrow keys and thus control the output signal up and down. When you finalise the point with , the unit returns to normal mode.

Password: Here you can choose a password between 0000 and 9999 in order to protect the unit against unauthorised modifications to the configuration. The unit is delivered default without password. If you have locked the unit with a password by mistake, you can always open the menu by using the master password 2008.

Language: In the menu "lang.setup" you can choose between 7 different language versions of help texts that will appear in the menu. You can choose between UK, DE, FR, IT, ES, SE and DK.

Auto diagnosis

The unit performs an advanced auto diagnosis of the internal circuits.

The following possible errors can be displayed in the front unit 4501.

CJ.ER - CJC sensor defect or CJC temperature outside range

FL.ER - Flash error

NO.CO - Connection error

IN.ER - Error levels on input

TY.ER - Configuration in 4501 does not match this product type

Selection of units

After choosing the input signal type you can choose the process units which will be shown in the display (see table). By selection of temperature input the process value is always displayed in Celsius or Fahrenheit. This is selected in the menu point after selection of temperature input..

ROUTING DIAGRAM

If no key is activated for 1 minute, the display will return to the default state 1.0 without saving configuration changes.

- ⊕ Increase value / choose next parameter
- ⊖ Decrease value / choose previous parameter
- Ⓚ Save the chosen value and proceed to the next menu
- Ⓚ Hold Ⓚ Back to previous menu / return to menu 1.0 without saving

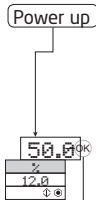

1.0

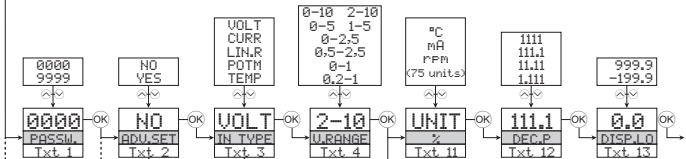

Continued on the next page

1.0 = Default state.

Line 1 shows

input signal.

Line 2 shows

UNITS.

By pressing ⊕ and

⊖ simultaneously

line 3 alternates

between f.Out

and TAG.

Line 4 shows

communication

status.

1.1 = Only if password-protected.

1.2 = Not valid for these

input signals:

0...20 mA and

voltage.

1.3 = Only if input signal is temperature.

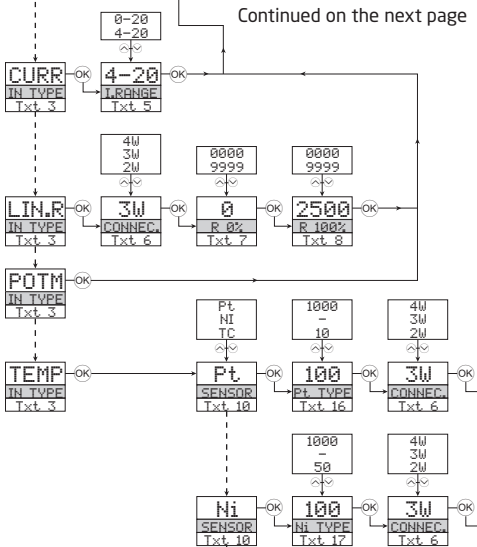

Continued on the page
Routing diagram ADV.SET



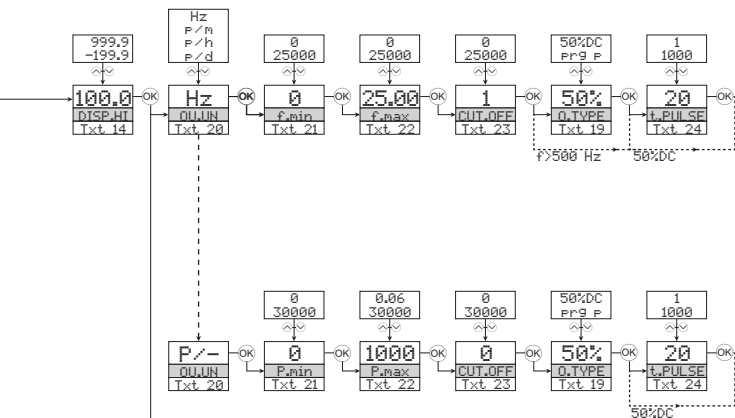

Selectable UNITS:

°C	hPa	kWh	mils	Pa
°F	Hz	L	min	°F
↕	in	L/h	mm	rPM
°C	in/h	L/min	mm/s	s
UNIT	in/min	L/s	mm/s ²	S
Txt 9	in/s	m	mol	t
	lps	m/h	MPa	t/h
	K	m/min	MV	uA
	kA	m/s	MW	um
ft/h	kg	m/s ²	MWh	uS
ft/min	kJ	m ³ /h	N	V
ft/s	kPa	m ³ /min	Ohm	W
g	kV	mA	P/day	Wh
gal/h	kW	mbar	P/h	yd
gal/min			P/min	[blank]
GW				
hp				

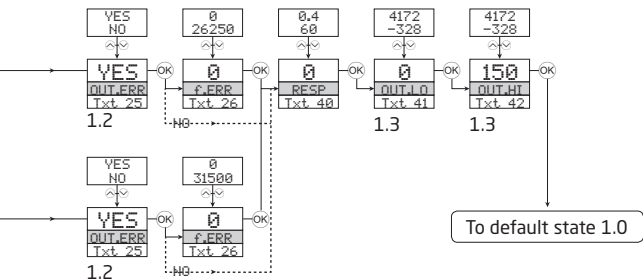

1.2 = Not valid for these
input signals:
0...20 mA and
voltage.

1.3 = Only if input signal
is temperature.

ROUTING DIAGRAM ADVANCED SETTINGS (ADV.SET)

2.0 In the submenu simulation (SIM) you must press **OK** to return to the default state 1.0.

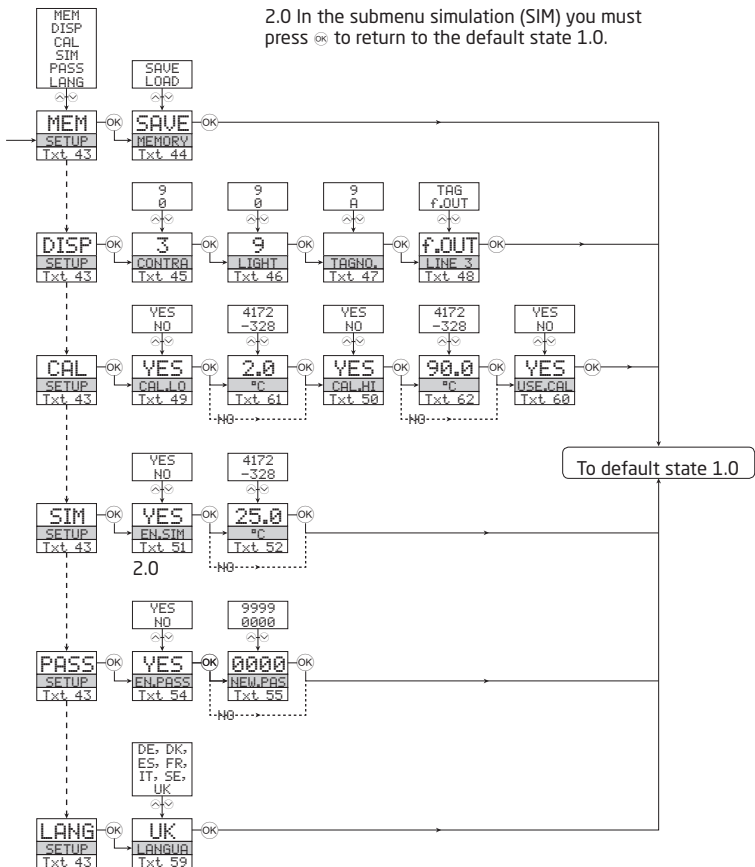

SCROLLING HELP TEXT IN DISPLAY LINE 3

- [01] Set correct password
- [02] Enter advanced setup menu?
- [03] Select temperature input
 - Select potentiometer input
 - Select linear resistance input
 - Select current input
 - Select voltage input
- [04] Select 0.0-1 V input range
 - Select 0.2-1 V input range
 - Select 0-2.5 V input range
 - Select 0.5-2.5 V input range
 - Select 0-5 V input range
 - Select 1-5 V input range
 - Select 0-10 V input range
 - Select 2-10 V input range
- [05] Select 0-20 mA input range
 - Select 4-20 mA input range
- [06] Select 2-wire sensor connection
 - Select 3-wire sensor connection
 - Select 4-wire sensor connection
- [07] Set 0% resistance value
- [08] Set 100% resistance value
- [09] Select Celsius as temperature unit
 - Select Fahrenheit as temperature unit
- [10] Select TC sensor type
 - Select Ni sensor type
 - Select Pt sensor type
- [11] Select display unit
- [12] Select decimal point position
- [13] Set display readout low
- [14] Set display readout high
- [16] Select Pt10 as sensor type
 - Select Pt20 as sensor type
 - Select Pt50 as sensor type
 - Select Pt100 as sensor type
 - Select Pt200 as sensor type
 - Select Pt250 as sensor type
 - Select Pt300 as sensor type
 - Select Pt400 as sensor type
 - Select Pt500 as sensor type
 - Select Pt1000 as sensor type
- [17] Select Ni50 as sensor type
 - Select Ni100 as sensor type
 - Select Ni120 as sensor type
 - Select Ni1000 as sensor type
- [18] Select TC-B as sensor type
 - Select TC-E as sensor type
 - Select TC-J as sensor type
 - Select TC-K as sensor type
 - Select TC-L as sensor type
 - Select TC-N as sensor type
 - Select TC-R as sensor type
 - Select TC-S as sensor type
 - Select TC-T as sensor type
 - Select TC-U as sensor type
 - Select TC-W3 as sensor type
 - Select TC-W5 as sensor type
 - Select TC-Lr as sensor type
- [19] Select 50% duty cycle output
 - Select programmable pulse time
- [20] Select Hz as output unit
 - Select pulses/minute as output unit
 - Select pulses/hour as output unit
 - Select pulses/day as output unit
- [21] Set output frequency for 0% input
- [22] Set output frequency for 100% input
- [23] Set low cut-off frequency
- [24] Set pulse time in milliseconds
- [25] Select no error action - output undefined at error
 - Select output at specific frequency on input error
- [26] Set output frequency on input error
- [40] Set response time in seconds
- [41] Set temperature for frequency output low
- [42] Set temperature for frequency output high
- [43] Enter language setup
 - Enter password setup
 - Enter simulation mode
 - Perform process calibration
 - Enter display setup
 - Perform memory operations
- [44] Load saved configuration into module
 - Save configuration in display front
- [45] Adjust LCD contrast
- [46] Adjust LCD backlight
- [47] Write a 6-character device TAG
- [48] Output frequency is shown in display line 3
 - Device TAG is shown in display line 3
- [49] Calibrate input low to process value?
- [50] Calibrate input high to process value?
- [51] Enter simulation mode?
- [52] Simulate input value
- [54] Enable password protection?
- [55] Set new password
- [59] Select language
- [60] Use process calibration values?
- [61] Set value for low calibration point
- [62] Set value for high calibration point



Displays Programmable displays with a wide selection of inputs and outputs for display of temperature, volume and weight, etc. Feature linearization, scaling, and difference measurement functions for programming via PReset software.



Ex interfaces Interfaces for analog and digital signals as well as HART signals between sensors / I/P converters / frequency signals and control systems in Ex zone 0, 1 & 2 and for some devices in zone 20, 21 & 22.



Isolation Galvanic isolators for analog and digital signals as well as HART signals. A wide product range with both loop-powered and universal isolators featuring linearization, inversion, and scaling of output signals.





























Temperature A wide selection of transmitters for DIN form B mounting and DIN rail devices with analog and digital bus communication ranging from application-specific to universal transmitters.



Universal PC or front programmable devices with universal options for input, output and supply. This range offers a number of advanced features such as process calibration, linearization and auto-diagnosis.



- 

www.preelectronics.fr

sales-fr@preelectronics.com
- 

www.preelectronics.de

sales-de@preelectronics.com
- 

www.preelectronics.es

sales-es@preelectronics.com
- 

www.preelectronics.it

sales-it@preelectronics.com
- 

www.preelectronics.se

sales-se@preelectronics.com
- 

www.preelectronics.com

sales-uk@preelectronics.com
- 

www.preelectronics.com

sales-us@preelectronics.com
- 

www.preelectronics.cn

sales-cn@preelectronics.com
- 

www.preelectronics.be

sales-be@preelectronics.com

Head office

Denmark
 PR electronics A/S
 Lerbakken 10
 DK-8410 Rønne

www.preelectronics.com
sales-dk@preelectronics.com
 tel. +45 86 37 26 77
 fax +45 86 37 30 85



QUALITY SYSTEM AND ENVIRONMENTAL
 MANAGEMENT SYSTEM
 DS/EN ISO 9001
 DS/EN ISO 14001

